

CF09 Bed Base - patent protected | Board - patent protected | Work - patent protected | Sofa - patent protected

GENERAL TECHNICAL INFORMATION

Double-function transforming system with vertical foldaway single and intermediate bed with the patented CF09 slatted bed base, with folding opening and safety mechanism to stop accidental opening and closing.

Folding mechanism with gas springs and device that cushions movements, completely embedded in the side of the structure, thanks to patented technology and special manufacturing.

The model, which is produced with a depth of 350 mm (with fabric headboard) or 623 mm (with wooden headboard, pillow compartment and shelves) is available in the Standard, Board (large desk), Work (table) and Sofa versions.

The system can stand alone or be integrated and coordinated with the elements of the Living and Young System programs.

Altea Standard is available in the single bed version with mattress W 850 mm and intermediate bed version with mattress W 1150 mm.

Altea Board features a patented maxi writing desk which uses a tilting movement to slide horizontally under the bed in the night-time configuration, without the need to remove any objects from the desk.

Altea Work features a mechanized table (W 700 mm x D 1200 mm x H 720 mm) for specific functions: foldaway opening for the table function, vertical closing flush against the front of the system to free up space and tilting movement so that it fits under the bed base in the night-time configuration.

Altea Sofa the backrest cushions are removed as the bed is opened, the sofa tilts backwards and sets under the bed.

The sofa is available in the version with a single seat cushion and with two types of seams on different armrests (W 40 mm and 160 mm). Removable cover.

- Wooden **frame** with adjustable nylon feet.
- **Bed base** with curved beech plywood slats mounted to the frame with adjustable nylon/rubber gaskets.
 - weight of Altea 90 bed base: Kg 28 - weight of Altea 120 bed base: Kg 31
 - weight of Altea 90 bed base + front panel Kg 40 - weight of Altea 120 bed base + front panel: Kg 47
- **Standard mattresses** H 180 mm single 850 mm x 1970 mm weight 14-16 kg, intermediate 1150 mm x 1970 mm weight 21-23 kg
Spring, memory basic, memory - independent spring coils, 7 zone memory, memory deluxe and latex versions.
For further information on mattresses, please refer to the specific page of the price list.
- Adjustable mattress **locking belts** in nylon with black nylon release fasteners.
- **Maximum liftable weight** (including mattress, blankets and pillows):
 - Altea 90 kg 59 - Altea 120 kg 72

Standard finishes:

- | | |
|--------------|--|
| Structure: | Melamine White, Oak Sabbia, Oak Moro, Perla, Tortora and lacquered as per Cleicoloursystem. |
| Front: | Melamine White, Oak Sabbia, Oak Moro, Perla, Tortora, Cemento, Glossy White Dialux, lacquered as per Cleicoloursystem. |
| Back: | Melamine White and lacquered as per Cleicoloursystem. |
| Decorations: | Prints, Quadra - Petalo – Wave, fixed configurations as per chapter "decorations" of the pricelist. |

N.B.: Made-to-measure sizes are not possible.

PATENTED CF09 BED BASE: Technological Innovation

- **The bed base** consists of laser cut, press-brake bent box-shaped sheet metal with die-cast components and a slatted wooden base (Fig. 1).
- **Safety:** Bed base safety device consisting of an automatic engagement locking pin. The auto-lock mechanism prevents accidental opening and closing of the bed, both in the vertical and in the horizontal position (Fig. 2).
Integrated opening lever between the side and front panel (Fig. 3) with automatic locking function of the open bed and manual unlocking for its closure (Fig. 4).
- **Mechanism and design:** Folding mechanism with gas springs and device that cushions movements, completely recessed in the side of the structure, thanks to patented technology and special manufacturing (Fig. 5).
- **Easy installation,** the gas spring automatic engagement device makes the bed base quick and easy to install.
- **Functionality and aesthetics:** No hardware required for front panel mounting (Fig. 6).
- **Adjustments:** to compensate floor level differences, the bed frame legs are height adjustable (Fig. 7A and 7B).



FIG. 1

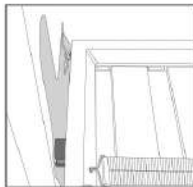

FIG. 2

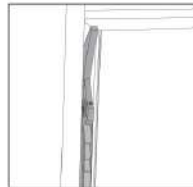

FIG. 3



FIG. 4

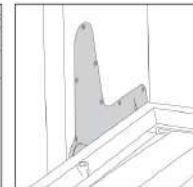

FIG. 5

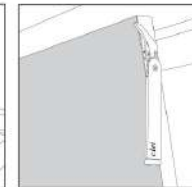

FIG. 6

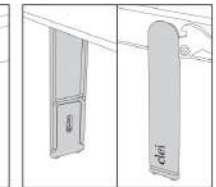

FIG. 7A

FIG. 7B

WARNINGS: Assembly and Safety

**IT IS MANDATORY TO FIX ALTEA, ALTEA BOARD AND ALTEA WORK TO THE WALL.
ALTEA SOFA IS SELF-SUPPORTING**

This product is delivered disassembled and provided with specific assembly instructions.

The product must be anchored to walls using 4 anchor points and must stand on perfectly level floors.

A hardware kit is supplied for assembly, but it does not include wall plugs which, in order to guarantee safety, must be chosen by the installer based on the type of wall or partition where the product is to be installed, and which the manufacturer does not know.

The installer is responsible for workmanlike assembly and testing of the product.

For further specific warnings, please see page 15 of this price list and the instruction booklet that is supplied with each product inside the packaging.

ALTEA 90 / 120 BOARD - D 35

Section

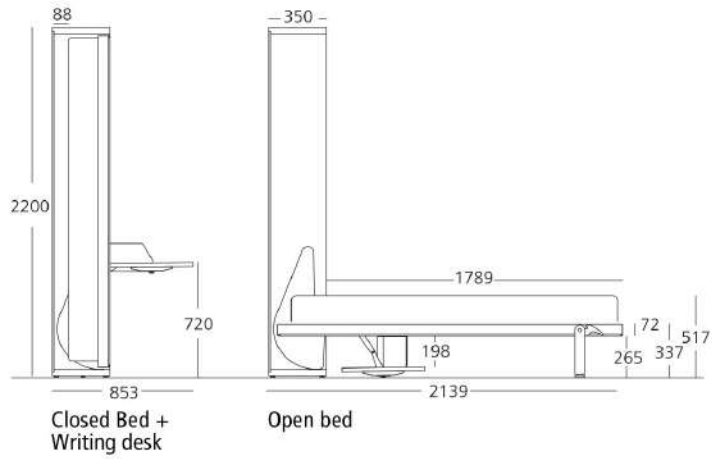
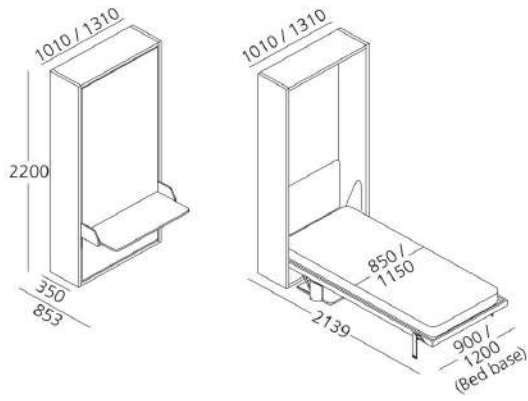

ALTEA BOOK 90 / 120 BOARD - D 62,3

Section

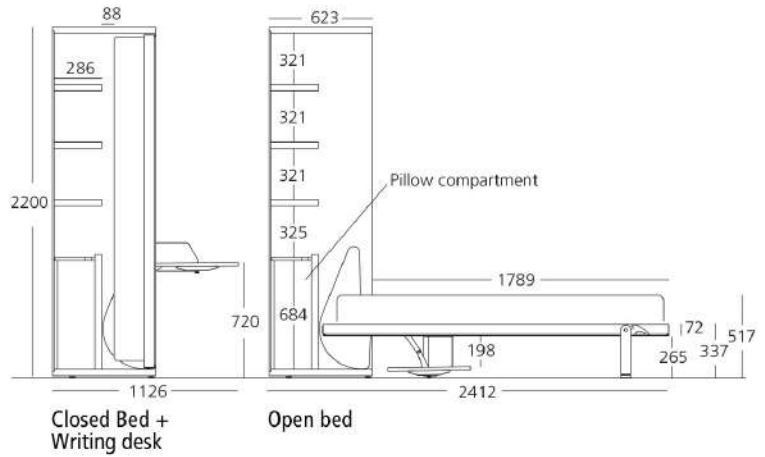
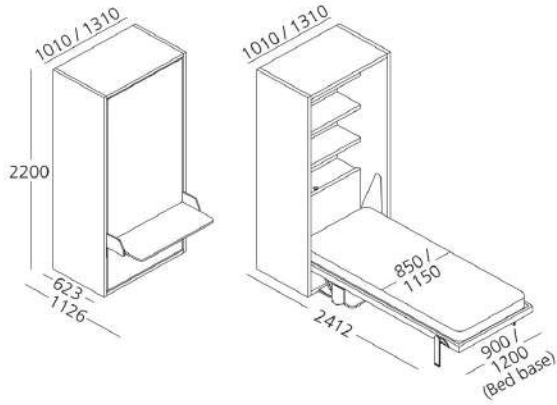

WRITING DESK TECHNICAL FEATURES

Tilting maxi writing desk with painted sheet metal sides and painted ribbed sheet metal structural support beam, both the same color as the bed base.
Maximum load: 35 kg equally distributed

